



Watt By Watt

WattByWatt Indoor Solar Cells

WattByWatt indoor solar cells use advanced perovskite technology to deliver flexible, efficient power for low-light applications. Available in multiple sizes and formats, our portfolio includes **Perovton™ W-MODEL and L-MODEL Minimodules** to meet different voltage and current requirements. Minimodules connect multiple cells in series for higher voltage, while cell size is optimized for the required current output.

If our standard cell sizes do not align with your design requirements, please contact sales@wattbywatt.com to discuss a custom solution tailored to your application.

Key Features

- ✚ Low climate footprint
- ✚ Output power up to $20 \mu\text{W}/\text{cm}^2$ at 200 lux
- ✚ Fabricated from synthetic materials and raw powders
- ✚ Customizable size and design
- ✚ Manufacturing in Canada
- ✚ Output voltage options for electronics integration

Minimodule model dimensions

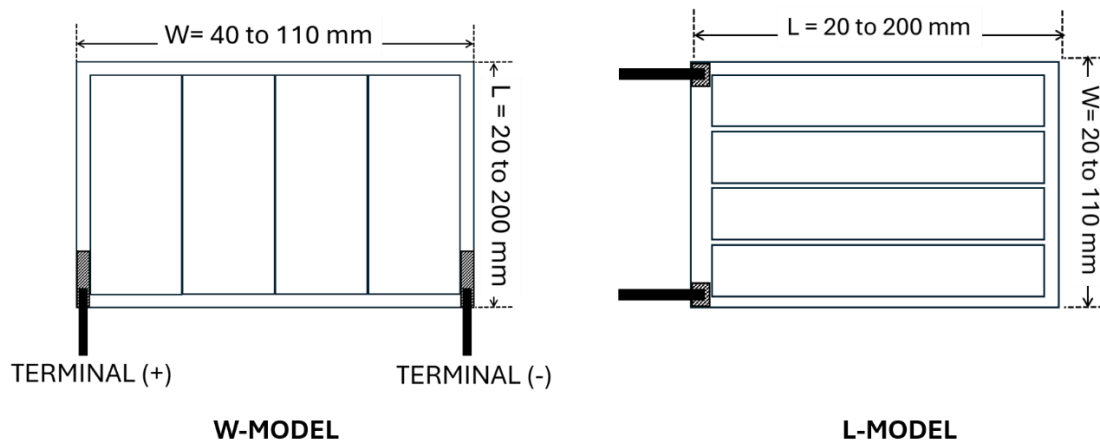



Watt By Watt

Minimodule Specifications

- ✚ Product category: Perovton™ W-MODEL minimodules
- ✚ Overall Dimensions: 7.8 cm x 4.8 cm
- ✚ Minimodule thickness: 3 to 5 mm
- ✚ Active Area: 22 cm²
- ✚ Device design: 4 cells connected in series
- ✚ Front Side: up to 3 mm thick conductive Glass
- ✚ Back Side: Glass or PCB
- ✚ Solder electrical leads

Table 1. Illuminance dependence of electrical characteristics of W-Model Perovton minimodules of a 6500K white LED, at 25°C and humidity between 25 and 35 %RH.

LUX LEVEL	V _{OC} (V)	J _{SC} (μA)	V _{MPP} (V)	J _{MPP} (μA)	P _{MPP} (μW)	PD _{MPP} (μW/cm ²)
90	3.4 - 3.6	64 - 66	2.8 - 3.1	56 - 61	160 - 190	7 - 9
200	3.5 - 3.6	145 - 148	2.9 - 3.1	125 - 140	365 - 420	16 - 20
500	3.6 - 3.7	355 - 365	3.0 - 3.1	299 - 340	900 - 1050	40 - 48
1000	3.7 - 3.8	680 - 700	3.0 - 3.2	585 - 650	1800 - 2020	80 - 92

Table 2. White LED color temperature dependence of electrical characteristics of W-Model Perovton™ minimodules under 200 lux.

White LED Color Temperature	V _{OC} (V)	J _{SC} (μA)	V _{MPP} (V)	J _{MPP} (μA)	P _{MPP} (μW)	PD _{MPP} (μW/cm ²)
Warm white: 3000K	3.62	156.75	3.07	143.55	440.50	20.02
Neutral white: 4000K	3.63	150.30	3.15	136.51	424.00	19.27
Cool white: 6500K	3.60	147.40	3.03	137.94	417.50	18.97



Watt By Watt

Current versus Voltage characteristics (W-Model)

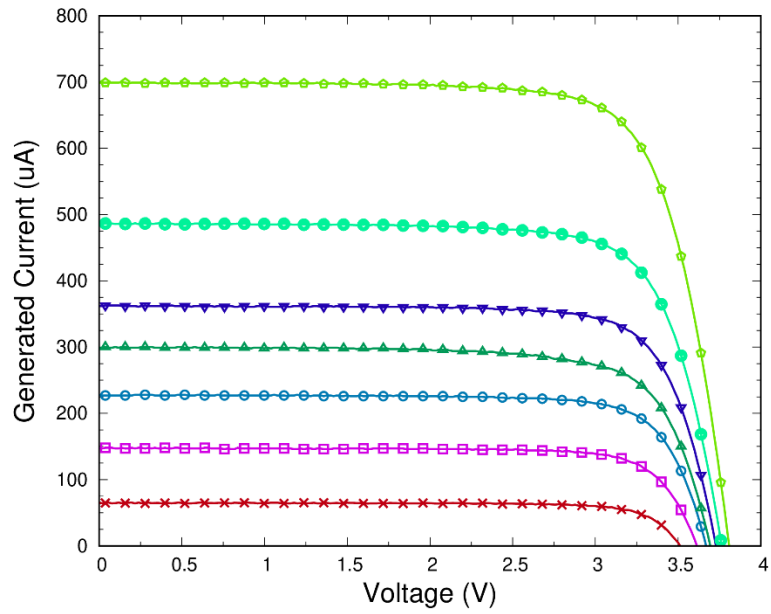

Corresponding Power versus Voltage characteristics

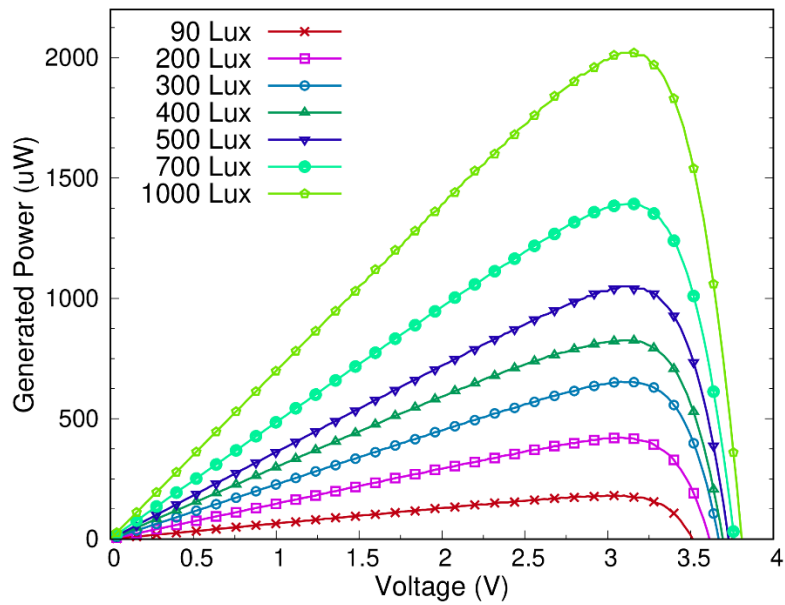
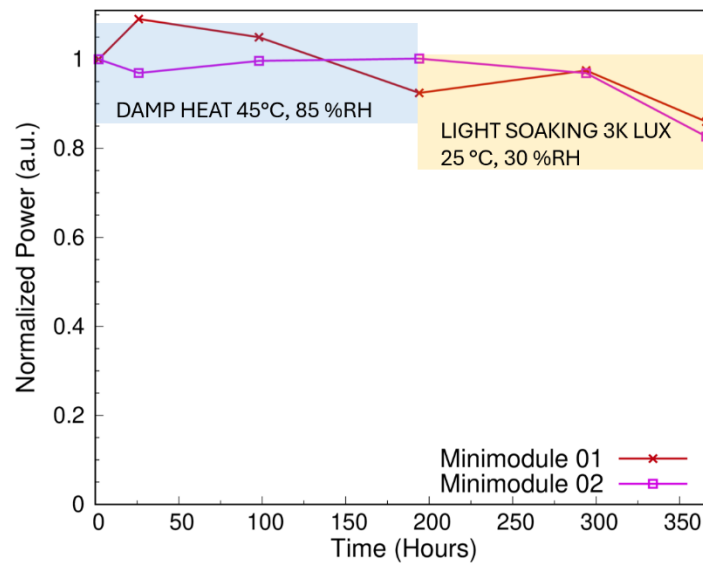

Table 3. Electrical characteristics of Perovton™ minimodule models under 200 lux of a 6500K white LED, at 25°C and humidity levels between 25 and 35 %RH.

Model	Overall Area	Active Area (cm ²)	V _{OC} (V)	J _{SC} (μA)	V _{MPP} (V)	J _{MPP} (μA)	P _{MPP} (μW)	PD _{MPP} (μW/cm ²)
L	7.8 cm x 4.4 cm	15.5	3.5 - 3.6	103 - 104	2.9 - 3.1	83 - 95	252 - 293	16 - 20
W	7.8 cm x 4.8 cm	22.0	3.5 - 3.6	145 - 148	2.9 - 3.1	125 - 140	365 - 420	16 - 20
XL	100 cm x 200 cm	101.5	3.4 - 3.5	650-665	2.8 - 3.0	595 - 604	1680 - 1800	16 - 18

Modules operation stability under high illuminance and accelerated lifetime tests

(Shelf stability: ≤ 5% power loss after 2,500 hours of dark storage at ambient conditions)





Important Notice and Limitations

- ✚ All data are informational, reflect typical values under standard conditions, and are not binding specifications or guarantees.
- ✚ Pre-series samples are provided “AS IS,” without any warranty or condition, express, implied, statutory, or otherwise, including merchantability, fitness for a particular purpose, title, or non-infringement.
- ✚ Pre-series samples are for research, development, demonstration, or evaluation only and are not finished, certified, or consumer-ready products.
- ✚ Pre-series samples should be handled by qualified personnel using appropriate engineering practices, procedures, and safeguards. *Consult the applicable Safety Data Sheet for hazard information.*
- ✚ WattByWatt does not warrant that samples produced through the Services meet regulatory, certification, safety, electromagnetic compatibility, or similar requirements. Samples are designed and manufactured to comply with RoHS and REACH regulations.
- ✚ Product and service information may change without notice. For current information, contact WattByWatt or visit www.wattbywatt.com.

Precautions for Handling Samples

- ✚ *This product presents potential health and environmental hazards and shall be used, handled, stored, and disposed of in accordance with applicable Canadian, European, and other relevant laws, regulations, and safety documentation, including the applicable Safety Data Sheet or equivalent documentation.*
- ✚ *Appropriate personal protective equipment, including chemical-resistant gloves, eye protection, and respiratory protection where applicable, shall be used by all personnel handling the samples. Samples shall be stored in a closed container within a ventilated cabinet or other suitable controlled environment.*
- ✚ *Waste samples shall be recycled or otherwise disposed of in accordance with applicable legal and environmental requirements. Samples that are no longer required, or that have experienced encapsulation failure, including glass breakage or detachment, should be returned for appropriate handling and disposal.*